

Roboshot Midjet MK4.5



The Jacon Roboshot Midjet MK4.5 is one of the most unique, compact self-contained shotcrete rigs of its kind in the world.

With an overall length of 4.85 meters and height of 2.75 meters, the compact Jacon Roboshot Midjet MK4.5 is extremely maneuverable and capable of being cage transported in one piece or driven underground. It is fitted with independent skid steer, four wheel hydraulic drive enabling it to turn in its own length and move around a mine with ease.

The Jacon Roboshot Midjet MK4.5 incorporates a long stroking large volume piston type shotcrete pump resulting in less pulsations and consequently less wear, a telescopic robotic shotcrete boom with 10 meters reach and parallel lance option, a chemical dosing system electronically metered with a totaliser for the end of shift, and the cordless remote control with cord backup gives the operator more safety and flexibility throughout the job.

The world's most compact, self-contained shotcreting rig, purpose built for roof support operations in underground mines.





Dimensions

- ✚ Length: 4850 mm
- ✚ Width: 1850 mm
- ✚ Height: 2750 mm
- ✚ Weight: 5900 kgs

Working Range

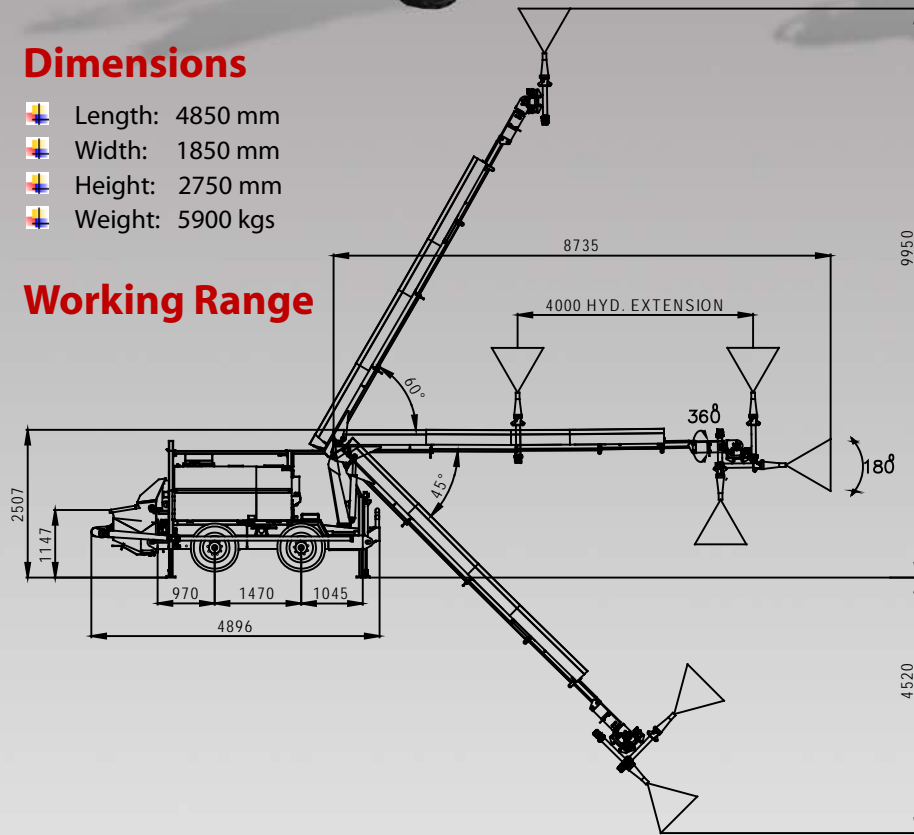

Specifications

- ✚ Caterpillar C4.4 Diesel engine 24V, rated at 94.5KW @ 2300 RPM.
- ✚ Hydrostatic transmission with hydraulic joystick control.
- ✚ Four wheel skid steering.
- ✚ Hydraulic four wheel disc brakes.
- ✚ Catalytic converter and spark arrester.
- ✚ Working and back up lights.
- ✚ Warning stroke lights.
- ✚ Jacon S64 concrete pump (150mm bore X 1140mm stroke)
- ✚ Rated output 20 cubic meters per hour.
- ✚ Actual output 0-18 cubic meters per hour depending on concrete mix and line set up.
- ✚ Fully robotic boom.
- ✚ Triple extension 9 meter reach slewing boom.
- ✚ Robotic head with 360 degree slew angle and 360 degree robot rotation.
- ✚ Oscillator on robotic head.
- ✚ Operating and parts manual.
- ✚ Peristaltic type chemical pump 0-7 liters per minute integrate with hydraulics.
- ✚ Solid tyres.
- ✚ Stainless steel chemical tank capacity 400 liters.
- ✚ Rexroth hydraulics.
- ✚ Radio remote control with corded back-up.
- ✚ Electronic chemical flow meter and totaliser.
- ✚ Hydraulic hopper grate vibrator.

Optional

- ✚ Hydrosclating Attachment.
- ✚ High Pressure wash down with Lance.
- ✚ Fire suppression system.

Specifications subject to change without notice.



Unit 1/ 36 Millrose Drive Malaga WA 6090 Phone: 08 9249 5544 Fax: 08 9249 5543
 Email: spareparts@moore-quip.com.au Web: www.moore-quip.com.au